

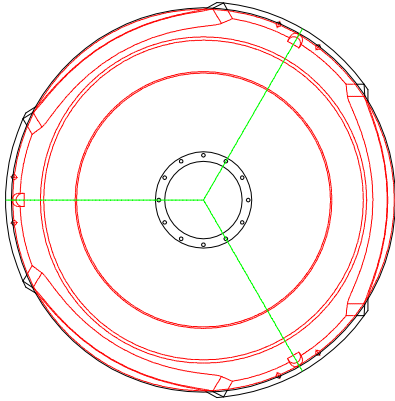

TOP VIEW

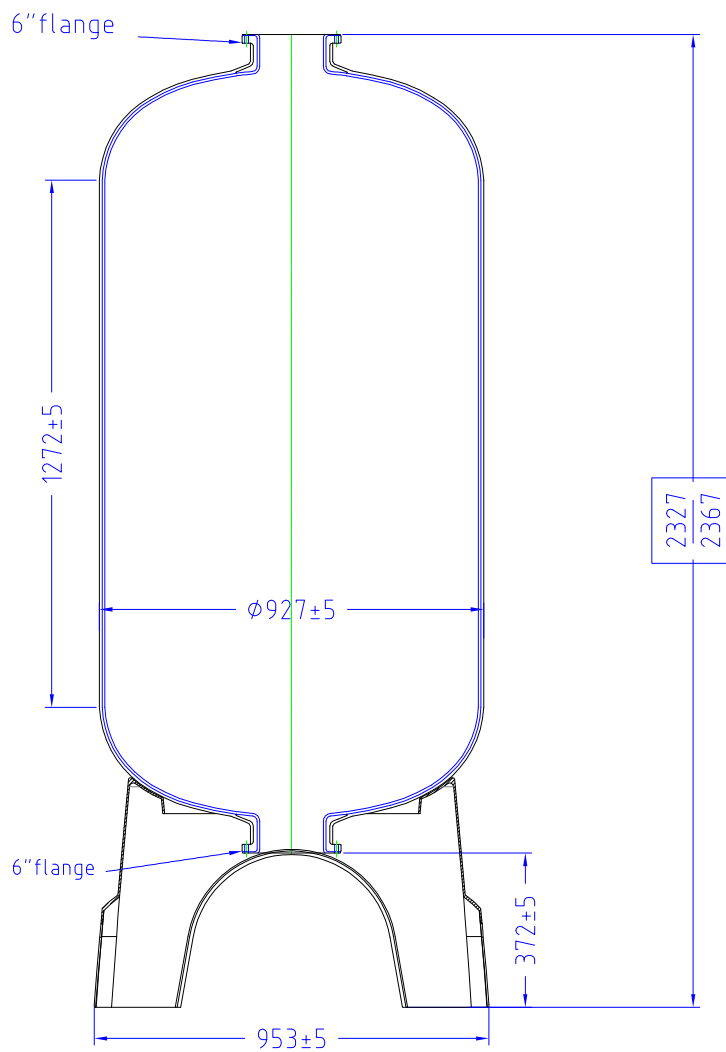

OFFSET VIEW



Material Inner shell : PE  
 Laminate : Blue epoxy - glass laminate  
 Operating pressure : min 0 bar - max 10 bar  
 Testing pressure : 11 bar  
 Operating temperature: min 1°C - max 65°C  
 Volume tank : ±852 liter  
 Weight empty tank : ±101 kg

		e	Redraw on new drawing layout	LVdS	29/05/02	
APPROVAL DRAWING		Location	REVISION DESCRIPTION	Approved	Date	
Customer :	 <b>Pentair Water</b> Industriepark Wolfstee Toekomstlaan 30 HERENTALS BELGIUM	Article :	Scale :	none		
Quantity ordered :		Cad filename :	Date :	26 November 2014		
Delivery date :		Model filename :	Drawn :	Arnaud Cuylen		
Approval signature by customer :		Approval date :	Remarks :	Approved :	SVC.	
		Description :	Material :	Projection :	A 4	
		NAT FLNG HOT-WATER-6''T+B,BASE		Drawing number :	C-3678-F7HW	