

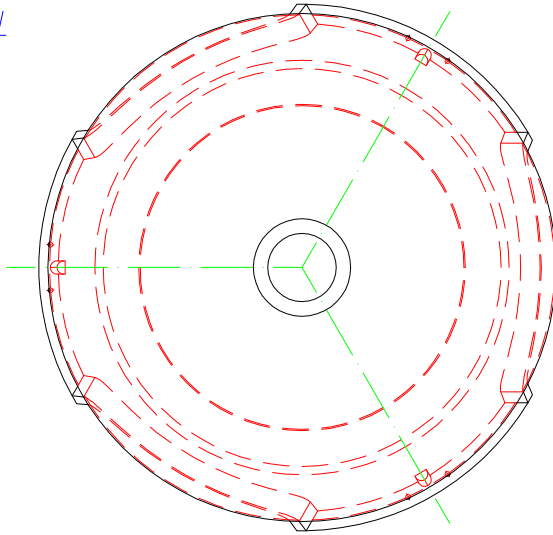

TOP VIEW

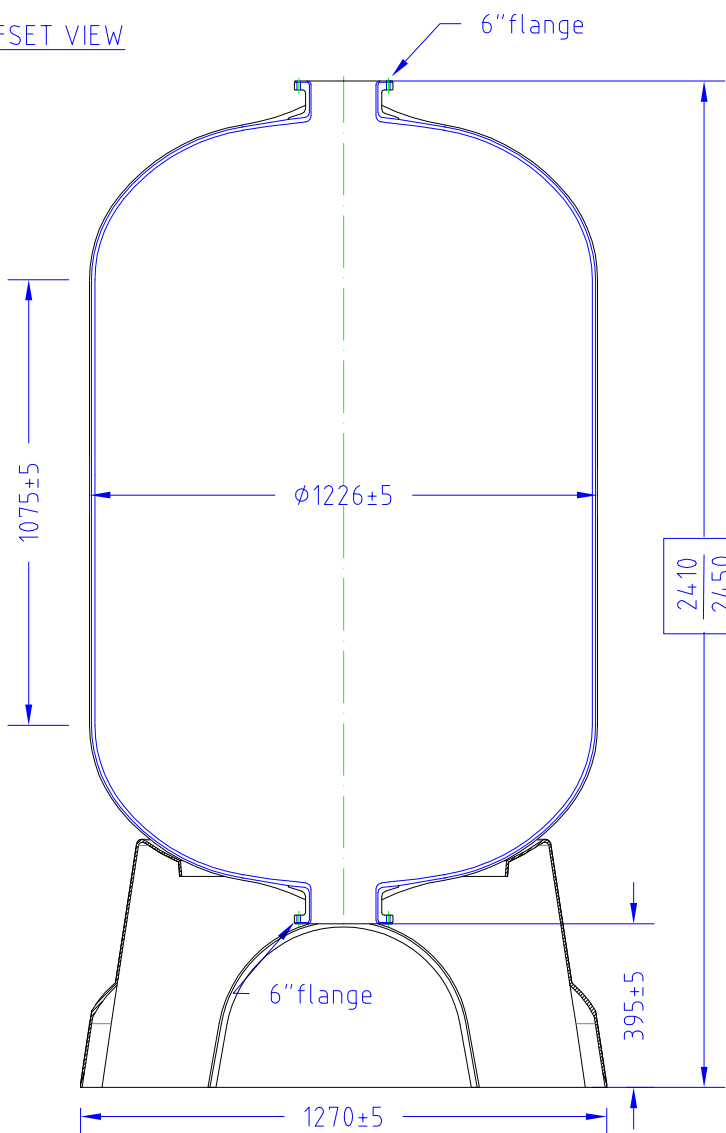

OFFSET VIEW

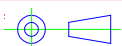

Material Inner shell : PE
 Laminate : Blue epoxy - glass laminate
 Operating pressure : min 0 bar - max 10 bar
 Testing pressure : 11 bar
 Operating temperature: min 1°C - max 65°C
 Volume tank : ±1830 liter /
 Weight empty tank : ±178 kg

APPROVAL DRAWING		Location	REVISION DESCRIPTION		Approved	Date
Customer :	/	 Pentair Water Industriepark Wolfstee Toekomstlaan 30 HERENTALS BELGIUM	Article :	Scale :	none	
Quantity ordered :	/		Cad filename :	Date :	24 November 2014	
Delivery date :	/		Model filename :	Drawn :	Arnaud Cuylen	
Approval signature by customer :	Approval date :		Description :	Remarks :	Approved :	GJ./SVC.
			Material :	Projection :		A 4
			see table		Drawing number :	C-4882-F7HW
			NAT FLNG HOT-WATER-6" T+B, BASE			